

# All Temperature Probes

## Important Installation Information

All steps must be read before installing a probe.

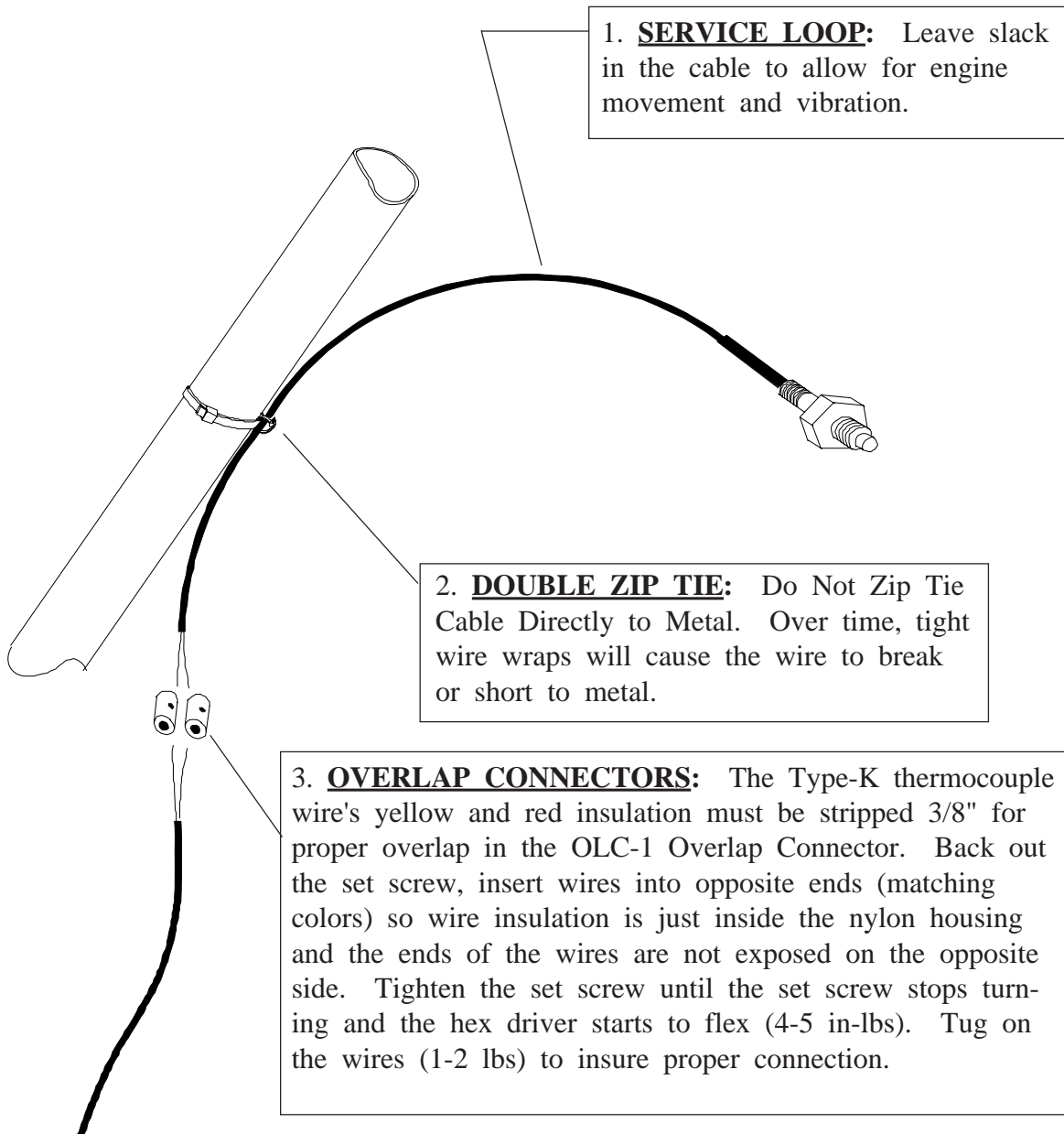

# *Electronics International Inc.*

## **P-111, P-112 and P-114 TIT Probe Depth Adjustment Procedure**

0522931 - TIT Depth

3/28/91  
Rev. D 8/26/08

**Important Note:** This probe can only be adjusted **ONE TIME**. Once the ferrule has been compressed, it cannot be removed. Please read the instructions below very carefully.

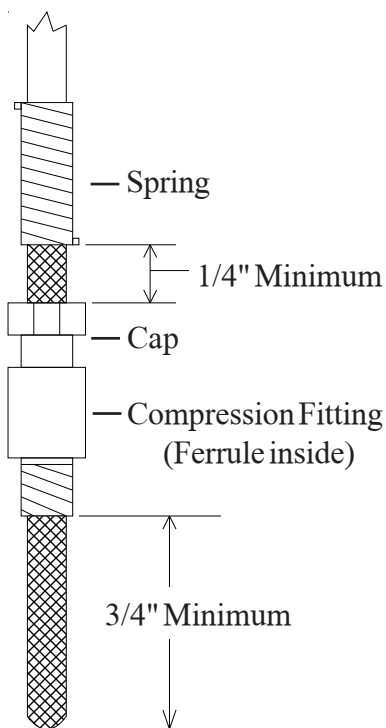

1. The probe should extend no less than 3/4" into the exhaust stack and no deeper than 1/2" from touching the opposite wall of the exhaust stack. Also, the spring should be more than 1/4" from touching the cap.
2. **Determine the depth of the exhaust probe so there will be no interference with the spring of the probe and so the probe does not obstruct the operation of anything in the exhaust stack. Also, the probe depth must fall within the parameters set forth above.**
3. Using a wrench, compress the ferrule by tightening the cap into the compression fitting.

**Note:** If this probe is to be used to measure temperatures in a pressurized environment (as would be the case when measuring oil temperature), **check the probe for leaks after starting the engine. Also, the compression fitting must be tightened on a portion of the probe that is free of any grooves. Do Not use E.I.'s P-110 EGT probe in a pressurized environment.**



***Electronics International Inc.***<sup>®</sup>



63296 Powell Butte Hwy • Bend, OR 97701 • Sales: (541) 318-6060 • Fax: (541) 318-7575

## LEANING TO TURBINE INLET TEMPERATURE

The turbine inlet temperature (TIT) typically is picked up 24 to 36 inches downstream from the exhaust port. This means the response time for the TIT can be considerably slower than for an exhaust gas temperature (EGT) reading, which normally is picked up 1-1/2 to 2 inches down from the exhaust port. A contributing factor to the delay in temperature readings using TIT probe is the actual temperature drift of the engine after a change is made in the mixture setting. This drift is due to piston domes and cylinder walls changing in temperature. To accurately lean, allow these temperatures to stabilize after making major adjustments in the mixture control. The TIT can take a little longer to register these temperature changes. Less accurate gauges cannot display these changes, which can result in an improperly leaned engine.

To lean more quickly, safely and efficiently, it's vital to monitor all your EGT's. This will allow you to lean to the proper cylinder and will provide you with an exceptional diagnostics tool. If you have not done so already, we urge you to upgrade your TIT instrument with one of our small primary remote switches to enable the instrument to monitor all of the EGT's in addition to the TIT. With this installation, your Electronics International, Inc. TIT instrument is still FAA approved as a primary engine instrument. Call us or write today for information on how to upgrade your TIT instrument to a full analyzer system.

**WARNING: Lycoming and Continental have published specific limits and recommendations regarding leaning that should be followed, including percentage of power, TIT limits and CHT limits. Although we offer general guidelines for leaning, these guidelines are in no way intended to replace or supersede your engine and/or airframe manufacturer's limits and recommendations. It is your responsibility to know your aircraft and engine's operating limits. Please refer to your POH and/or your engine manual for proper leaning methods for your aircraft/engine.**

To speed up the TIT leaning process, make the major mixture changes without waiting for the TIT temperatures to stabilize. "Pre-lean" the mixture to a temperature close to the peak TIT, around 50°F rich of peak. Once you have reached a "pre-lean" temperature allow the temperatures to stabilize before proceeding with your leaning process. After the temperatures have stabilized, make very small changes in the mixture control setting, waiting 10 to 15 seconds between changes. At some point, the TIT will stop rising when a small change is made in the mixture control. If done properly, you have found your peak TIT. Generally, most engines peak at the same TIT every time.