

Electronics International Inc.

63296 Powell Butte Hwy
Bend OR 97701
(541) 318-6060

MVP-50T
Instructions for Continued Airworthiness

Document No: 06201101
Revision: A: 06/23/11

Prepared by:

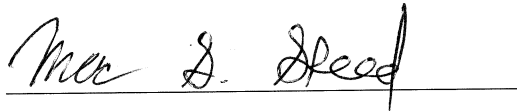

06/23/11

Mac S. Speed



06/23/11

Ron Roberts

Notice

This document and the information contained herein are the property of Electronics International Inc. Any reproduction, disclosure or use thereof is prohibited except as authorized in writing by Electronics International Inc. The recipient of this document accepts the responsibility for maintaining the confidentiality of the contents of this document.

Table of Contents

Section	Page
1.0 REVISION HISTORY	3
2.0 LIST OF EFFECTIVE PAGES.....	3
3.0 DISTRIBUTION OF REVISIONS.....	3
4.0 INTRODUCTION	3
5.0 SYSTEM DESCRIPTION	4
5.1 PROBES, TRANSDUCERS AND MODULES	4
5.2 EXTENSION CABLES.....	4
5.3 ENGINE DATA CONVERTER (EDC-33T).....	4
5.4 DISPLAY UNIT (MVP-50T).....	5
5.5 MVP-50T SYSTEM PARTS LIST	5
6.0 APPLICABLE DOCUMENTS.....	5
7.0 CONTROL & OPERATION INFORMATION	6
8.0 AIRWORTHINESS LIMITATIONS.....	6
9.0 INTERIOR PLACARDS.....	7
10.0 CHARTS AND WIRING DIAGRAMS	7
11.0 OVERHAUL TIME LIMITS	7
12.0 MAINTENANCE INSTRUCTIONS.....	7
13.0 PROTECTIVE TREATMENT	7
14.0 SERVICING.....	7
15.0 REMOVAL	7
16.0 INSTALLATION AND REPLACEMENTS	8
17.0 TROUBLESHOOTING	8
18.0 SPECIAL INSTRUCTIONS.....	8
19.0 SPECIAL INSPECTION REQUIREMENTS.....	8
20.0 SPECIAL TOOLS	8

1.0 Revision History

REVISIONS			
Rev.	Reason/Description	Requested/ Changed By	Date
New		N/A	06/21/11
A	Added Distribution of Revisions. Removed reference to Order 8110.54A, Part 23 Appendix G and OI 1206061. Added fuel calibration procedure.	AEG	06/23/11

2.0 List of Effective Pages

This document is controlled and revised as a complete unit and does not contain pages of various revisions. All pages are of the same revision as indicated on the cover page and also indicated at the bottom of each subsequent page. The effective pages consist of the sections as noted in the Table of Contents.

3.0 Distribution of Revisions

Notification of changes to this ICA will be sent to all MVP-50T owners on record. The changed document will be available at www.Buy-Ei.com. Paper copies will be available on request, contact Electronics International at (541) 318-6060 or www.buy-ei.com

4.0 Introduction

This document contains the instructions for continued airworthiness (ICA). This ICA was written in the format contained in the GAMA Specification No. 2 which was specified by FAA Order 8110.54A. This ICA conforms to the requirements specified by Part 23, Appendix G and FAA Order 8110.54A. The FAA guidance includes sections that are not applicable to the MVP-50T system, only applicable sections have been addressed in this document.

5.0 System Description

The MVP-50T consists of a multifunction glass panel engine monitoring and display system featuring screens to display aircraft system functions and secondary flight data. This system performs monitoring tasks only; it does not perform any engine or aircraft system controlling functions.

The MVP-50T System consists of four major components: the Display Unit (MVP-50T), the Engine Data Converter (EDC-33T); the probes; transducers and modules; and the wiring and extension cables.

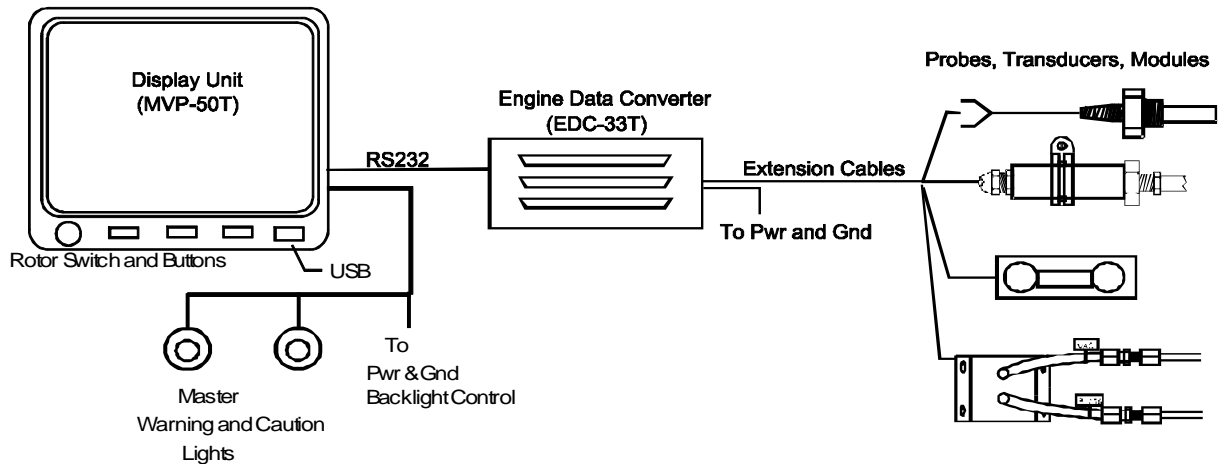

5.1 Probes, Transducers and Modules

These components are used to measure N1, N2, ITT, Torque, Oil Pressures, Fuel Pressure, Fuel Flow, Oil Temperature, OAT, Volts, Amps, Fuel Level, Hydraulic Pressure, Boom Pressure, Vacuum and G-Force. The analog and pulsed signals produced by the transducers and/or probes are routed through the extension cables to the various EDC-33T inputs.

5.2 Extension Cables

The extension cables route the signals from the probes, transducers and modules to the EDC-33T. For the ITT, Oil Temp and OAT functions the wires are of type K thermocouple.

5.3 Engine Data Converter (EDC-33T)

The EDC-33T is a 4.5" x 3.5" x 2.2" module that incorporates three 37-pin D-sub connectors. The EDC-33T incorporates 13-temperature channels, 9-high impedance pressure channels, 1-amp channel, 2-RPM channels, 4-capacitive fuel level channels, 4-resistive fuel level channels and a fuel flow channel. The EDC-

33T channels convert signals from the probes, transducers and modules to a digital format. This data is transmitted via a two-wire RS422 cable to the MVP-50T Display Unit.

5.4 Display Unit (MVP-50T)

The MVP-50T receives, processes and displays the RS422 data on a TFT color display. In addition, the MVP-50T receives GPS data and monitors the external back light control line. Also, the MVP-50T transmits fuel flow and fuel level data to a GPS and controls the external Master Caution and Warning Lights. In addition, secondary flight data screens are provided to assist the pilot in safe flight.

5.5 MVP-50T System Parts List

MVP-50T	Display unit
EDC-33T	Engine Data Converter
CBL-4D-6-MVP	Four Wire Cable w/D-Sub Pins
RFLM-4-xx	Resistive Fuel Level Module
P-128	OAT Temperature Probe
S-300	300 Amp Shunt
S-100	100 Amp Shunt
AL-1R	Red External Warning Light
AL-1Y	Yellow External Warning Light
PT-05Diff	Vacuum
PT-30GA	Fuel Pressure Transducer
PT-100GA	Oil Pressure Transducer
PT-100GA	Torque Pressure Transducer
PT-3000S	Hydraulic Pressure Transducer
FT-180	Fuel Flow Transducer
P-300C	Capacitive Fuel Level Probe
P-300M	Magnetic Float Sensor
G-Meter	G-Force Transducer

6.0 Applicable Documents

The following documents are listed for reference only. Each document is applicable only to the extent specified herein.

II 1211061

MVP-50T Installation Instructions

7.0 Control & Operation Information

All of the engine and aircraft functions monitored by the MVP-50T are displayed on the Main Screen. The Main Screen is displayed after power-up. All other screens display advisory information only.

Fuel Level calibration is performed during the initial installation of the MVP-50T and should not require recalibration. Changing or repairing the MVP-50T display and/or EDC-33T will not affect fuel level calibration. However, if a fuel probe is replaced, fuel level calibration will be required.

To calibrate the fuel level for a specific fuel tank, perform the following:

1. The fuel tank must be calibrated with the wings level and the aircraft set for level flight pitch. Start with an empty tank.
2. While viewing the Main Screen on the MVP-50T press the Menu Button. Select the "System Configuration Screens Menu" at the bottom of the screen. When you select this screen it will prompt you for your Level #1 Password (Maintenance).
3. Enter the Password "00200"
4. Select the "Fuel Tank Calibration" screen.
5. At the top of the screen select the fuel tank to be calibrated.
6. Wait for the "Current Sensor Count" to settle. Select the "Empty" calibration point. Transfer the "Current Sensor Count" to the "Sensor Count Field" by selecting "YES" in the Use "Current Count?" field.
7. Fill the tank to the next calibration point and repeat step 6 until all calibration points have been processed. Sensor counts should increase more than 5 counts for every gallon of fuel added to the tank.
8. Once the calibration is completed, press the Exit button three times to return to the main screen.

8.0 Airworthiness Limitations

There are no new or additional airworthiness limitations when installing the MVP-50T system.

The Airworthiness Limitations section is FAA approved and specifies maintenance required under Secs. 43.16 and 91.403 of the Federal Aviation Regulations unless an alternative program has been FAA approved.

9.0 Interior Placards

There are no markings or placards required in conjunction with the MVP-50T System.

10.0 Charts and Wiring Diagrams

All installation diagrams, schematics and charts are located in the MVP-50T Installation Instructions (II 1211061).

11.0 Overhaul Time Limits

The MVP-50T system and accessories have no overhaul time limits.

12.0 Maintenance Instructions

Maintenance checks should be performed every 100 hour and/or at the annual inspection. Check all system components for the following: leaks on or around transducers, loose fittings, chaffing and/or breakage of any cables or wires and loose connections. Probes must be checked for proper installation. This includes tightening any hose clamps or fittings. Also, verify the unit is operating and functioning properly and the readings are correct and appear accurate.

13.0 Protective Treatment

There are no applications of protective treatments required for the MVP-50T system and its components.

14.0 Servicing

Servicing is "on condition" only. There are no field adjustments or calibration requirements for the MVP-50P instrument after it has been properly installed, checked off and signed-off by the respective authority. All servicing of the MVP-50T system and accessories must be accomplished by Electronics International (EI). Probes, transducers, modules and the display unit are limited to removal and replacement with EI manufactured new or EI repaired components. Location and access to the components are described in the MVP-50T Installation Instructions (II 1211061).

For servicing information contact Electronics International Inc. at (541) 318-6060 or www.Buy-Ei.com.

15.0 Removal

Guidance on removal of the MVP-50T system and/or accessories is provided in the MVP-50T Installation Instructions (II 1211061). Removal must be performed in accordance with applicable airworthiness standards.

16.0 Installation and Replacements

Installation of the MVP-50T and/or accessories must be performed in accordance with the MVP-50T Installation Instructions (II 1211061) and in accordance with applicable airworthiness standards.

17.0 Troubleshooting

Troubleshooting the MVP-50T system and accessories, including probes, transducers and modules, must be performed in accordance with the Troubleshooting Section found in the MVP-50T Installation Instructions (II 1211061). Troubleshooting is limited to identification of a defective component. A components internal workings should only be repaired by Electronics International inc.

18.0 Special Instructions

There are no special instructions required for the MVP-50T System.

19.0 Special Inspection Requirements

There are no special inspection requirements required for the MVP-50T System.

20.0 Special Tools

There are no special tools required for working on the MVP-50T System.