

Fuel Flow (*Only*) Functional Module (FM-Flow) Installation Instructions and Wiring Diagram

1110985

II 1111981 Supplement

11/10/98

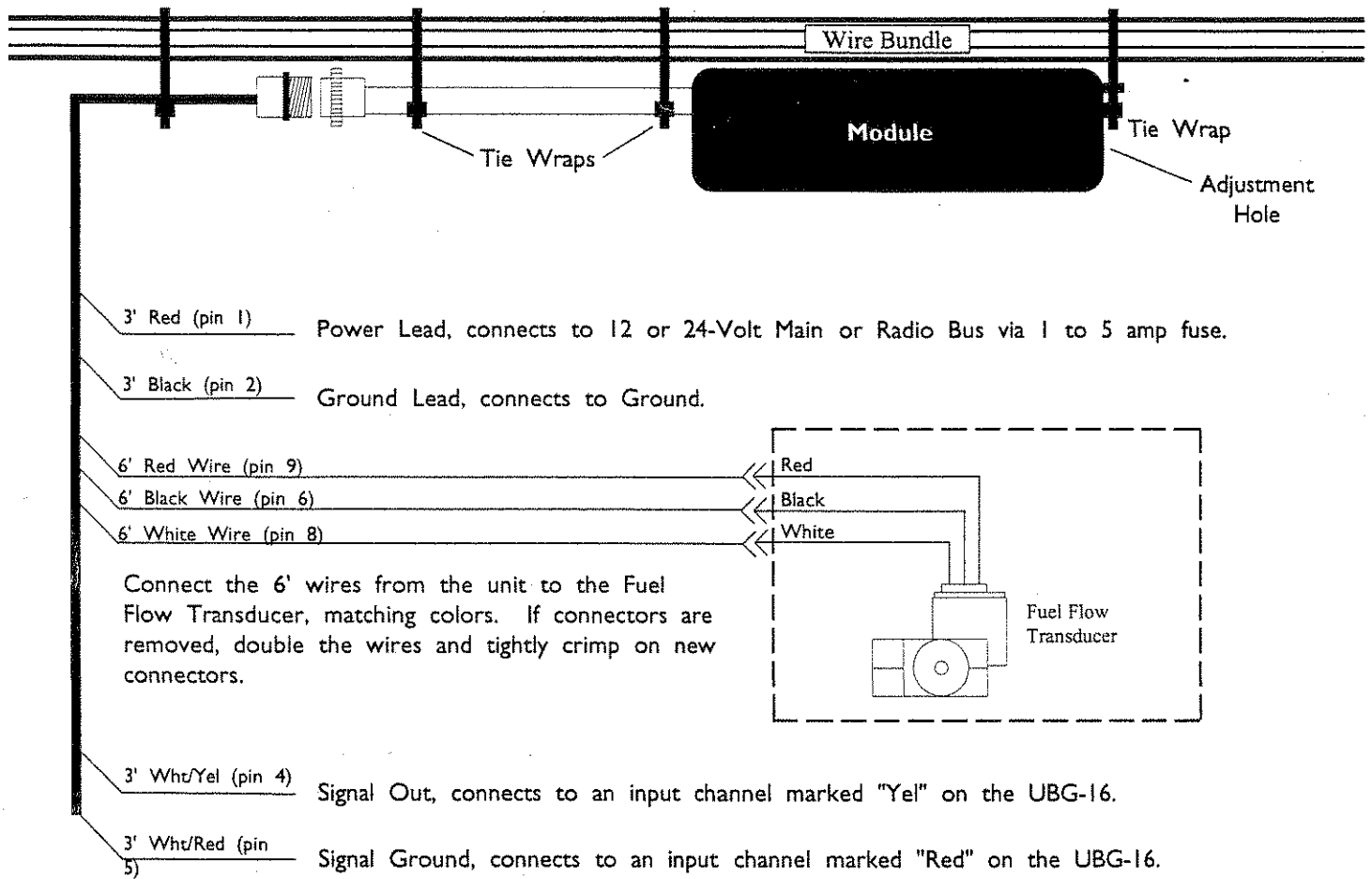

1. Install the Fuel Flow Transducer:

The fuel flow transducer installation complies with STC SA00068SE (FP-5) and STC SA00680SE (UBG). Mount the Fuel Flow Transducer using the appropriate drawing at the back of this manual.

Aircraft Configuration	Drawing #:	Page
Fuel injected engine without a fuel return line from the fuel servo.	1229932 or 1229931	6, 5
Fuel injected engine with a fuel return line from the fuel servo.	0415941	8
Carbureted engine with a fuel pump and no fuel return line.	1229932 or 1229931	6, 5
Carbureted engine with a fuel pump and a fuel return line (Requires an FFDM-1 Module).	1229932 or 1229931 and 1015941	6, 5, 7
Carbureted engine with a gravity feed fuel system (Requires an FT-90 Fuel Flow Transducer).	1229932 or 1229931	6, 5

The instructions listed below must be followed when installing a Fuel Flow Transducer.

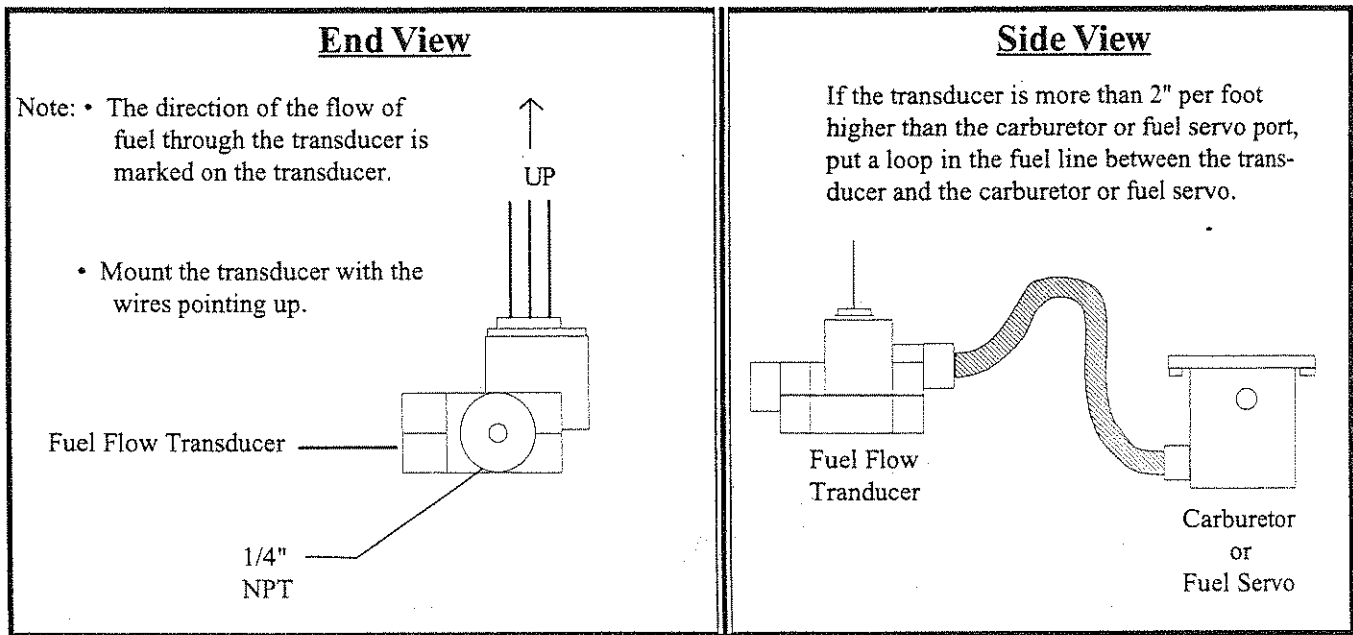

Note: If your engine is equipped with a fuel return line from the carburetor back to the fuel tank, you will need to install two flow transducers... one in the feed line from the fuel pump to the carburetor and one in the return line from the carburetor back to the fuel tank. Also, a Fuel Flow Differential Module (FFDM-1) will need to be installed. See drawings 1229932 and 1015941 at the back of this manual.

- The transducer output port should be mounted lower, even with or no more than 2" per foot higher than the carburetor inlet port (or fuel servo on a fuel injected engine). If this is not possible, a loop should be put in the fuel line between the Fuel Flow Transducer and the carburetor or fuel servo (see diagram below).
- Do not remove the caps on the flow transducer until the fuel hoses are ready to be installed.
- The flow of fuel through the transducer must follow the direction marked on the transducer.
- The flow transducer must be mounted so the wires exiting the transducer are pointing up.
- Before connecting any hoses, thoroughly clean them and insure that they are free of any loose material. High air pressure may be used, **however, do not allow high air pressure to pass through the flow transducer.**

2. Mount the Module and Connect the 9-Pin Wire Harness:

Tie wrap the FM-Flow Module to a wire bundle under the aircraft instrument panel. Connect the 9-Pin Wire Harness to the Module.

3. Route the Power and Ground Wires:

Route the red wire in the wire harness to the aircraft's 12 or 24-volt radio or main bus as applicable, via a 1 to 5 amp fuse. Route the black wire in the wire harness to a good ground. **Tie wrap these wires so they do not obstruct the freedom of travel of any controls.**

4. Route the Fuel Flow Transducer Wires:

The wire harness includes 6' red, black and white wires bundled together. Route and connect these 6' wires to the appropriate fuel flow transducer wires.

Be sure the connectors mate properly. If the tab inside the male connector gets bent, it can wedge itself between the red nylon and metal female receptacle. This can result in an intermittent connection after about a month or more. If the connectors are removed several times the female connector can become loose. If this happens use a pair of needlenose pliers and tighten the metal receptacle inside the female connector.

Note: A dab or grease or two drops of oil on the red connectors will protect them for many years.

Any excess wires can be rolled up and tie wrapped under the instrument panel. Tie wrap these wires so they do not obstruct the freedom of travel of any controls. If you decide to cut these wires to a specific length, strip each wire and double the wires over. An extra set of connectors is provided in the kit. Double crimp each connector. Doubling the wires over and a good crimp are critical.

5. Route the Signal Out and Ground Wires to the UBG-16:

Route the White/Yellow wire to the appropriate left or right channel marked "Yel" on the UBG. Route and connect the White/Red wire to the appropriate channel marked "Red" on the UBG-16. Tie wrap all wires so they do not obstruct the freedom of travel of any controls.

UBG Extension Cable Harness (Left or Right)
Back View (wire side)

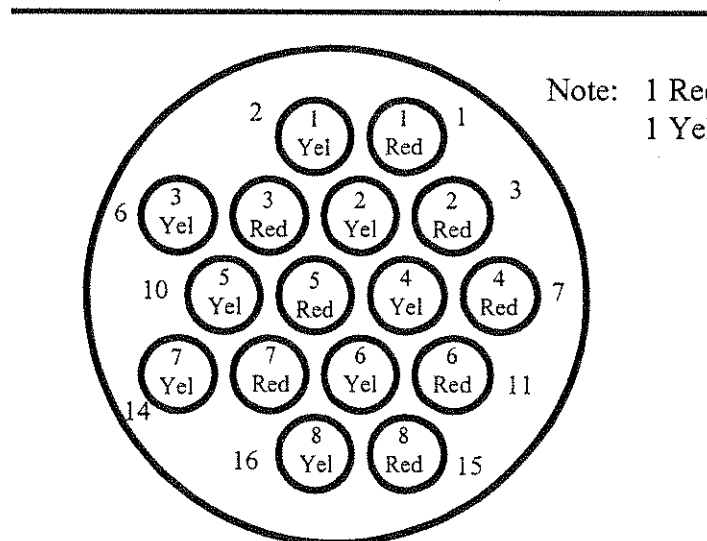

Note: 1 Red = Channel #1 Red wire (Gnd)
1 Yel = Channel #1 Yel wire (Signal)

6. Calibrating the Fuel Flow Functional Module:

The FM-Flow Module has been calibrated to the flow transducer which was shipped with the module and should not require adjustment. Although, in some cases, such as in carbureted engines, the installation can affect the calibration of the flow transducer, in which case an adjustment may be necessary. There is a hole at one end of the module in order to make any adjustment. At 12 Gal/Hr, one clockwise turn on the adjustment pot will increase the fuel flow approximately 1 Gal/Hr.

Specifications and Operating Features

Model:

FM-Flow (Fuel Flow Functional Module)

Case Dimensions:

3" x 2" x 1"

Weight:

Unit Only: 2.8 Oz.

Flow Transducer: 3.0 Oz.

Environmental:

Meets TSO C44a

Power Requirements:

7.5 to 35 Volts, 1/10 Amp.

Accuracy:

Flow: 2% or better in accordance with TSO C44a.

Resolution:

Fuel Flow: .1 Gal/Hr.

Fuel Flow Transducer, Standard (FT-60):

Range: 0.6 to 60 GPH

Linearity: %1 (8 to 60 GPH)

K Factor: Approx. 85,000

Pressure Drop: 1.2 PSI at 30 GPH

4.8 PSI at 60 GPH

Working Press: 200 PSI

Min. Burst Press: 2000 PSI

Temp. Range: -65°C to 125°C

Fuel Ports: 1/4" Female NPT

Fuel Flow Transducer, Special (FT-90):

Range: 3 to 90 GPH

K Factor: Approx. 19,500

Pressure Drop: .31 PSI at 30 GPH

2.8 PSI at 90 GPH

Working Press: 200 PSI

Min. Burst Press: 2000 PSI

Temp. Range: -65°C to 125°C

Fuel Ports: 1/4" Female NPT

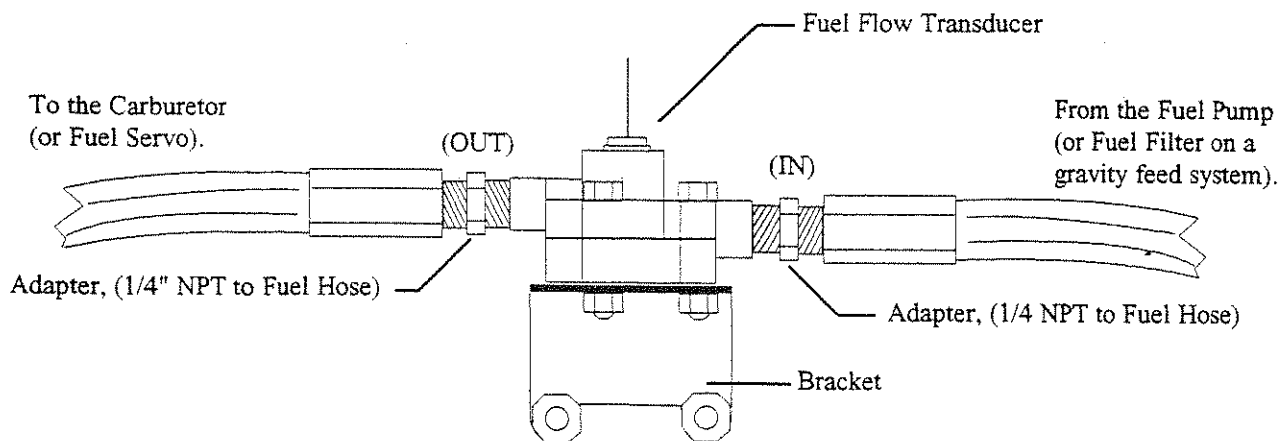

Mounting Procedure:

1. Find a convenient location on the fire wall (away from any hot exhaust pipes) and mount a bracket for the Fuel Flow Transducer. Check both sides of the fire wall for clearance before drilling any holes.
2. Mount the Fuel Flow Transducer onto the Bracket. **You must use the FT-90 Fuel Flow Transducer on a gravity feed system or for any engine that has over 300 H.P.** The FT-90 Transducer is marked "Model 231" on the top of the transducer. **If the Transducer is mounted within 6" of an exhaust pipe, the Flow Transducer must be wrapped with Fire Sleeving.**
3. Remove the fuel hose which goes from the Fuel Pump (or the Fuel Filter on a gravity feed system) to the Carburetor (or Fuel Servo).
4. Purchase two new hoses, using one from the fuel pump (or the Fuel Filter) to the Fuel Flow Transducer (making provisions for the fuel pressure transducer as necessary) and the other from the Fuel Flow Transducer to the carburetor (or fuel servo). **There must be flexible hose in and out of the Transducer.** The hoses must meet TSO-C53a Type C or D FAA specification. **The new hoses must be the same size as the current hose in the aircraft.** Two sources for fittings and fabricated hoses are:

Sacramento Sky Ranch Inc.
 (916) 421-7672
 Fax: (916) 421-5719

OR

Varga Enterprises Inc.
 (602) 963-6936
 FAX: (602) 899-0324

5. **Read the Installation Instructions for important installation considerations.**

Drawn By: R.R.	<i>Electronics International Inc.</i> Installation of a Fuel Flow Transducer on the Fire Wall and in the fuel line from the fuel pump to the carburetor or fuel servo. Note: <u>Not applicable</u> for a fuel injected engine with a fuel return line (see D/N 0415941).		
Approved By: R.R.			
Scale: None			
Material:			
Next Assembly:			
P/N:	Date: 12/29/93	Rev: C 4/20/94	D/N: 1229931

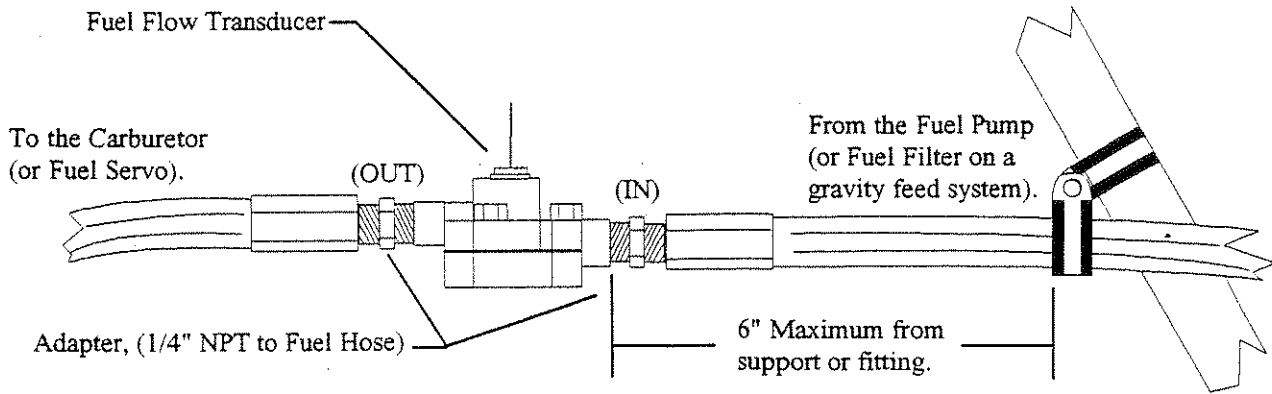

Mounting Procedure:

1. Find a convenient location within 6" of a hose support or fitting and away from any hot exhaust pipes to suspend the Fuel Flow Transducer. The hose support or fitting may be on the input or output line of the Flow Transducer.
2. Remove the fuel hose which goes from the Fuel Pump (or the Fuel Filter on a gravity feed system) to the Carburetor (or Fuel Servo).
3. Purchase two new hoses, using one from the fuel pump (or the Fuel Filter) to the Fuel Flow Transducer and the other from the Fuel Flow Transducer to the carburetor (or fuel servo). **There must be flexible hose in and out of the Transducer.** The hoses must meet TSO-C53a Type C or D FAA specification. **The new hoses must be the same size as the current hose in the aircraft.** Two sources for fittings and fabricated hoses are:

Sacramento Sky Ranch Inc.
 (916) 421-7672
 Fax: (916) 421-5719

OR

Varga Enterprises Inc.
 (602) 963-6936
 FAX: (602) 899-0324

4. Mount the Fuel Flow Transducer in the fuel line. **You must use the FT-90 Fuel Flow Transducer on a gravity feed system or on any engine that has over 300 H.P.** The FT-90 Transducer is marked "Model 231" on the top of the transducer. **If the Transducer is mounted within 6" of an exhaust pipe, the Flow Transducer must be wrapped with Fire Sleeving.**
5. **Read the Installation Instructions for important installation considerations.**

Drawn By: R.R.	<i>Electronics International Inc.</i> Installation of a Fuel Flow Transducer suspended in the fuel line <u>from the fuel pump to the carburetor or fuel servo.</u> Note: <u>Not applicable</u> for a fuel injected engine with a fuel return line (see D/N 0415941).		
Approved By: R.R.			
Scale: None			
Material:			
Next Assembly:			
P/N:	Date: 12/29/93	Rev: C 4/20/95	D/N: 1229932

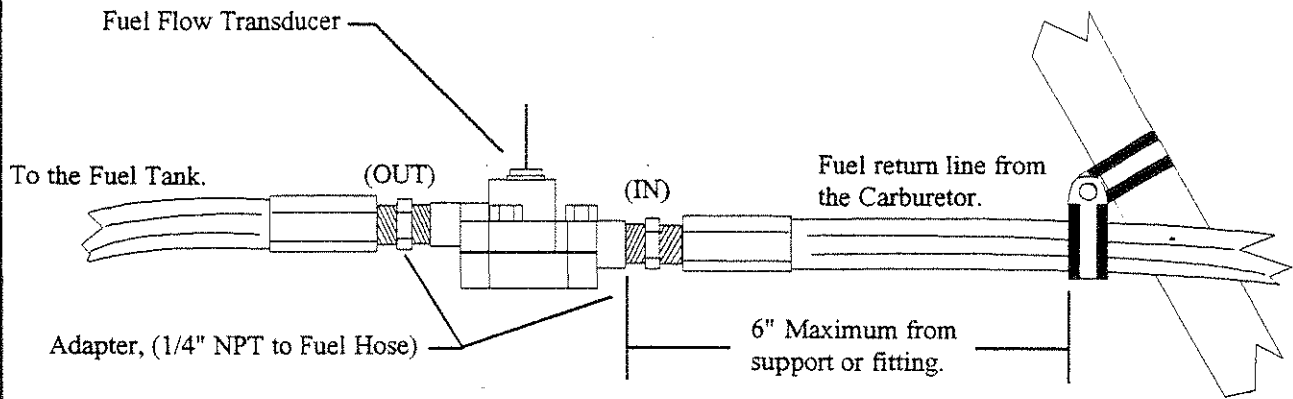

Mounting Procedure:

1. Find a convenient location within 6" of a hose support or fitting and away from any hot exhaust pipes to suspend the Fuel Flow Transducer. The hose support or fitting may be on the input or output line of the Flow Transducer.
2. Remove the return fuel hose which goes from the Carburetor to the Fuel Tank.
3. Purchase two new hoses, using one from the Carburetor to the Fuel Flow Transducer and the other from the Fuel Flow Transducer to the Fuel Tank. **There must be flexible hose in and out of the Transducer.** The hoses must meet TSO-C53a Type C or D FAA specification. **The new hoses must be the same size as the current hose in the aircraft.** Two sources for fittings and fabricated hoses are:

Sacramento Sky Ranch Inc.
 (916) 421-7672
 Fax: (916) 421-5719

OR

Varga Enterprises Inc.
 (602) 963-6936
 FAX: (602) 899-0324

4. Mount the Fuel Flow Transducer in the fuel return line. **You must use the FT-90 Fuel Flow Transducer on any engine that has over 300 H.P.** If the Transducer is mounted within 6" of an exhaust pipe, the Flow Transducer must be wrapped with Fire Sleeving.
5. **Read the Installation Instructions for important installation considerations.**

Drawn By: R.R.	<i>Electronics International Inc.</i> Installation of a Fuel Flow Transducer suspended in the <u>fuel return line</u> from the carburetor to the fuel tank. Note: <u>Only applicable</u> for installation on aircraft with a fuel return line from the <u>Carburetor</u>.		
Approved By: R.R.			
Scale: None			
Material:			
Next Assembly:			
P/N:	Date: 10/15/94	Rev:	D/N: 1015941

To the Flow Divider.

Mounting Procedure:

1. Find a convenient location between the Fuel Servo and Flow Divider and away from any hot exhaust pipes to suspend the Fuel Flow Transducer.
2. Remove the fuel hose which goes from the Fuel Servo to the Flow Divider.
3. Purchase two new hoses, using one from the Fuel Servo to the Fuel Flow Transducer and the other from the Fuel Flow Transducer to the Flow Divider. **There must be flexible hose in and out of the Fuel Transducer.** The hoses must meet TSO-C53a Type C or D FAA specification. **The new hoses must be the same size as the current hose in the aircraft.** Two sources for fittings and fabricated hoses are:

Sacramento Sky Ranch Inc.
 (916) 421-7672
 Fax: (916) 421-5719

OR

Varga Enterprises Inc.
 (602) 963-6936
 FAX: (602) 899-0324

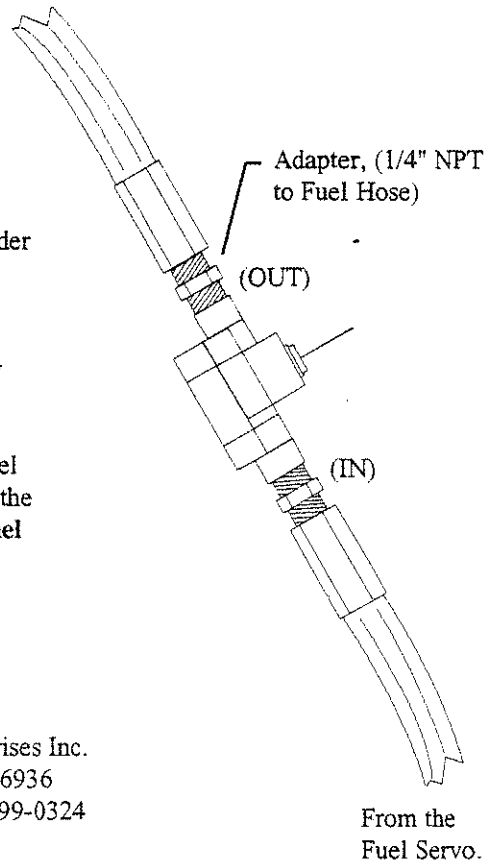

From the Fuel Servo.

4. Mount the Fuel Flow Transducer in the fuel line. **You must use the FT-90 Fuel Flow Transducer on any engine that has over 300 H.P.** If the Transducer is mounted within 6" of an exhaust pipe, the Flow Transducer must be wrapped with Fire Sleeving.
5. **Read the Installation Instructions for important installation considerations.**

Drawn By: R.R.	<i>Electronics International Inc.</i> Installation of the Fuel Flow Transducer suspended in the fuel line <u>between the Fuel Servo and the Flow Divider.</u> Note: <u>Only applicable</u> for installation on aircraft with a fuel return line from the Fuel Servo.		
Approved By: R.R.			
Scale: None			
Material:			
Next Assembly:			
P/N:	Date: 4/15/94	Rev: A 4/20/95	D/N: 0415941