

# Electronics International

1030031

## FT-90 Flow Transducer (Gold Cube)

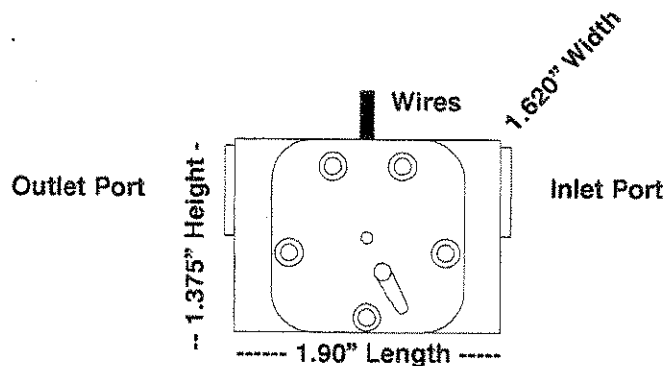

### Warnings:

If the installation of the Gold Cube FT-90 transducer is not covered on an STC, you must perform the flow and pressure tests in FAA document A.C. 23-16 to insure safe and proper engine operation. Installation must conform to aircraft standards and practices (A.C. 43.13). DO NOT attempt to remove the screws in this transducer. Doing so will cause the screws to break and render the Gold Cube FT-90 unsafe.

### General:

The Gold Cube FT-90 has considerably less pressure drop than other units on the market and a blocked rotor does not effect pressure drop. Also, the overall accuracy and linearity of Gold Cube FT-90 is superior to most other flow transducers. The Gold Cube FT-90's design vacates bubbles and is not nearly as susceptible to debris as other units on the market. Additionally, rotor pin to jewel clearances are matched on every unit resulting in a single K-factor for all units. Note: Installation configuration can effect the K-factor.

### Identification:

The Gold Cube FT-90 can be identified by its gold anodized body and cube shape.

### Electrical Interface:

The Gold Cube FT-90 interfaces with the FP-5(L) and most other fuel flow instruments. The Gold Cube FT-90 incorporates an open collector output, the same configuration as the Floscan units.

1030031

FT-90 Continued

### Mechanical Interface:

The Gold Cube FT-90 has 1/4" NPT ports. DO NOT EXCEED a torque of 25 ft. lbs. when installing fittings into the transducer. The FT-90 should NOT be installed with the wires pointing DOWN (the best situation is with wires pointing UP). Also, the fuel line on the outlet port should not drop down after exiting the transducer. Both of these configurations can trap bubbles in the transducer causing jumpy readings. The inlet port, outlet port and flow direction are marked on the top of the FT-90.

### Specifications:

Model: FT-90 (Gold Cube)

K-Factor: 33800 Pulses/Gal (installation configurations can effect the K-Factor) (use 338 when programming the K-Factor in the FP-5(L)).

Pressure Drop (with 6.0 Lbs/Gal fuel), (blocked or unblocked rotor) : 0.5PSI @ 63 Gal/Hr  
2.0PSI @ 127 Gal/Hr

To Calculate Pressure Drop:  $P = \frac{(\text{Flow})^2 \times W_f}{48114}$       P = Pressure Drop in PSI  
Flow = Fuel Flow in Gal/Hr.  
Wf = Weight of Fuel in Lbs/Gal

Fuel Flow Range: 2 to 125+ Gal/Hr.

Fuel Flow Over Range (with no damage to transducer): Unlimited

Linearity: +/- 1% over an engines normal operating range.

Repeatability: +/- 1/4%

Burst Pressure: 4000+ psi

Recommended Maximum Working Pressure: 1000 psi

Temperature Range: -65°C to 125°C

Weight: 5.26 Oz.

Life Expectancy: 10,000 Hrs. min.

FAA PMA'd and STC'd